

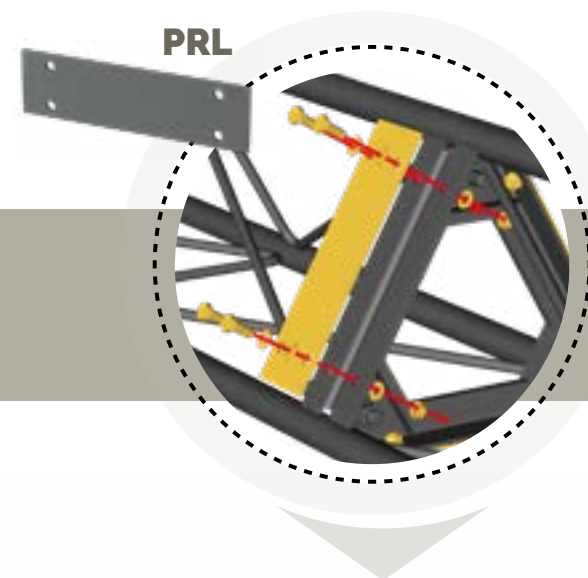

# CORRETTO MONTAGGIO // CORRECT ASSEMBLY

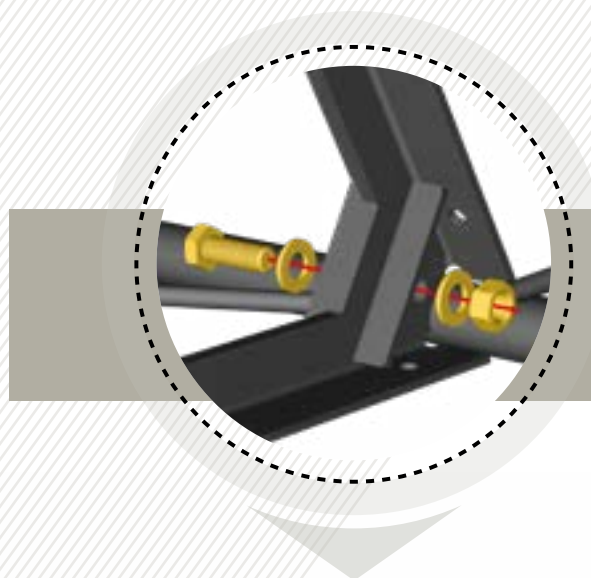

Utilizzare solo viti in  
acciaio 8.8 // Use 8.8  
steel screws only



Senza **PIASTRE DI RINFORZO** //  
Without **REINFORCEMENT PLATES**

Per **carichi laterali** di bassa intensità //  
For **light side loads**.

Con **PIASTRINE DI RINFORZO** //  
With **REINFORCEMENT PLATES**

Per **carichi più elevati** // For **heavier loads**.

Con **PIASTRE DI RINFORZO  
LATERALI** // With **REINFORCEMENT  
SIDE PLATES**

Per **carichi particolarmente elevati** o in presenza  
di **vento** // For **heavy loads** or in case of **high winds**.

## COME SELEZIONARE I CODICI // HOW TO CHOOSE THE RIGHT CODE



**SENZA PIASTRE  
DI RINFORZO  
WITHOUT  
REINFORCEMENT  
PLATES**

**PIASTRINA DI RINFORZO  
REINFORCEMENT PLATE**

**PIASTRA DI RINFORZO LATERALE  
SIDE REINFORCEMENT PLATE**

CODICE TRALICCIO // TRUSS CODE	SEZIONE // SIDE LENGTH	BULLONERIA IN ACCIAIO 8.8 // 8.8 STEEL NUTS AND BOLTS	BULLONERIA IN ACCIAIO 8.8 // 8.8 STEEL NUTS AND BOLTS	CODICE PIASTRINA // PLATE CODE	BULLONERIA IN ACCIAIO 8.8 // 8.8 STEEL NUTS AND BOLTS	CODICE PIASTRA LATERALE // SIDE PLATE CODE
<b>T12S</b>	△ 12,5 cm	<b>M6 x 16</b>	-	-	-	-
<b>T20S</b>	△ 20 cm	<b>M8 x 20</b>	<b>M8 x 25</b>	<b>T20S.PRT</b>	-	-
<b>T25S</b>	△ 25 cm	<b>M8 x 20</b>	<b>M8 x 25</b>	<b>T25S.PRT</b>	<b>M6 x 20</b>	<b>T25S.PRL</b>
<b>T30S</b>	△ 30 cm	-	<b>M12 x 35</b>	<b>T30S.PRT</b>	<b>M8 x 25</b>	<b>T30S.PRL</b>
<b>T40H</b>	△ 40 cm	-	<b>M12 x 40</b>	<b>T40H.PRT</b>	<b>M12 x 30</b>	<b>T40H.PRL</b>



### FISSAGGIO T40H T40H FIXING

Il traliccio triangolare T40H presenta due "alette" aggiuntive per un fissaggio migliore // The T40H triangular truss is fitted with two extra "wings" for better fixing.

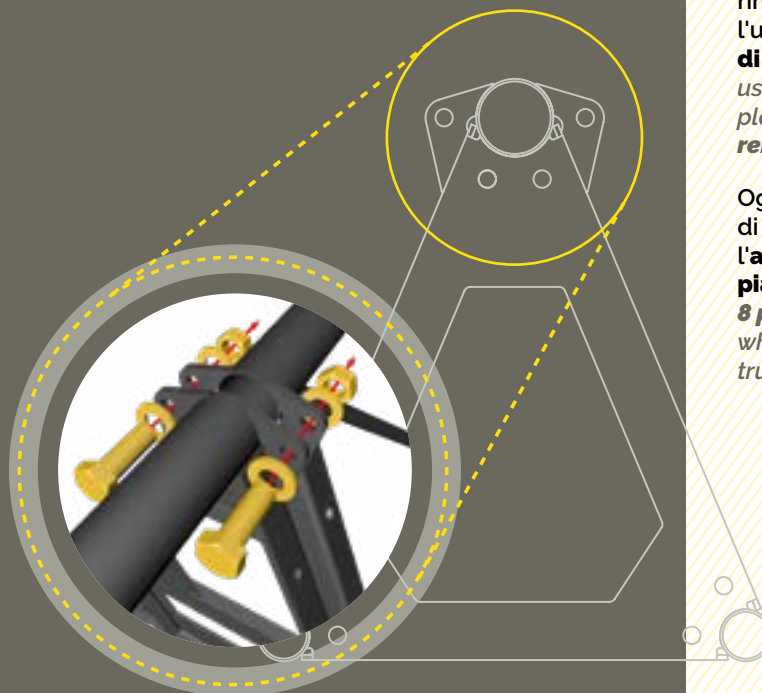

A supporto delle piastre di rinforzo laterale si consiglia l'utilizzo anche delle **piastrine di rinforzo** // We recommend using the reinforcement plates in addition to the **side reinforcement plates**.

Ogni accoppiamento di tralici prevede l'**assemblaggio di 8 piastrine** // **8 plates are required** when connecting two trusses.

## COME SELEZIONARE I CODICI // HOW TO CHOOSE THE RIGHT CODE



PIATTO PER GIUNZIONE TRALICCI  
CONNECTING BRACKET

CODICE TRALICCIO // TRUSS CODE	SEZIONE // SIDE LENGTH	BULLONERIA IN ACCIAIO 8.8 // 8.8 STEEL NUTS AND BOLTS	CODICE PIATTI DI GIUNZIONE // CONNECTING BRACKET CODE
Q20S	□ 20 cm	M8 x 40	Q20S.CPG
Q20H	□ 20 cm	M8 x 45	Q20H.CPG
Q25S	□ 25 cm	M8 x 45	Q25S.CPG
Q25H	□ 25 cm	M8 x 45	Q25H.CPG
Q30S	□ 30 cm	M12 x 60	Q30S.CPG
Q30H	□ 30 cm	M10 x 80	Q30H.CPG
Q40H	□ 40 cm	M12 x 80	Q40H.CPG
Q50H	□ 50 cm	M12 x 90	Q50H.CPG

Ogni accoppiamento di tralici prevede l'**assemblaggio di una coppia di piatti** // A pair of brackets is required when **connecting two trusses**.

## STAFFA PER CARICHI SOSPESI // BRACKET FOR HANGING LOADS

La nuova staffa per carichi sospesi è lo **strumento più flessibile per appendere i fari al traliccio**. È formata da due piastre unite fra loro tramite una vite filettata, che possono **scorrere lungo il lato del traliccio**. Questo permette di **fissare il faretto e di aggiustarne la posizione una volta acceso e direzionato** //

*This new bracket is the most versatile device to hang spotlights from trusses. It is made up of two plates fastened with a threaded screw. The plates can slide along the side of the truss so that spotlights can be set up once they are fastened and switched on.*

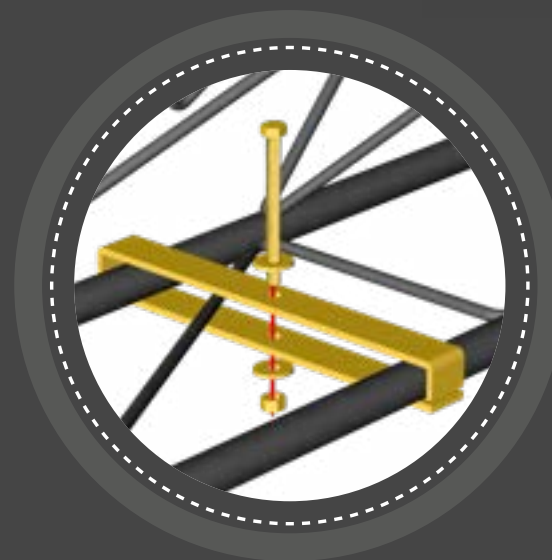
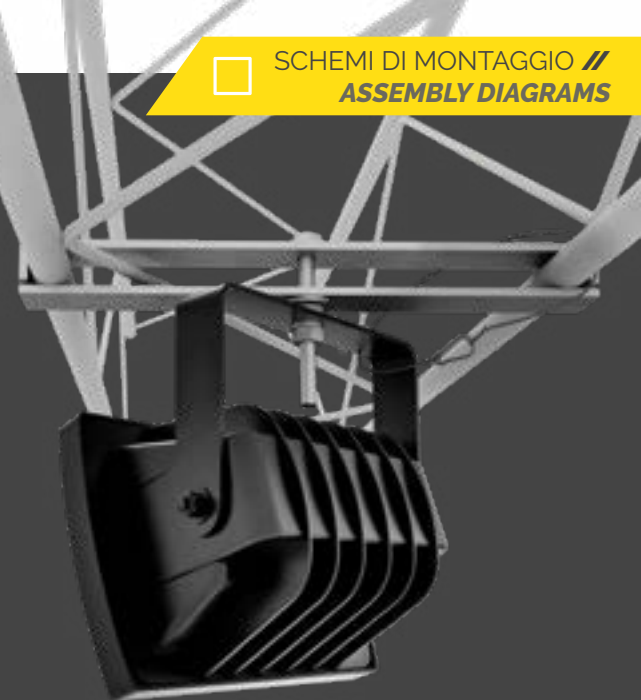

CODICE STAFFA // BRACKET CODE	KG
T12S.SCS	0,1 kg
T20S.SCS	0,2 kg
T25S.SCS	0,3 kg
T30S.SCS	1,7 kg
T40H.SCS	4,8 kg
Q20S.SCS	0,2 kg
Q20H.SCS	0,3 kg
Q25S.SCS	0,3 kg
Q25H.SCS	0,3 kg
Q30S.SCS	1,7 kg
Q30H.SCS	1,7 kg
Q40H.SCS	4,8 kg
Q50H.SCS	6,0 kg

# GANCI E ACCESSORI // HOOKS AND ACCESSORIES

Per l'appendimento dei fari, Selvolina propone una gamma completa di ganci di varie forme e dimensioni // *Selvolina offers a wide range of hooks of different shapes and sizes for hanging spotlights.*

Esempio di utilizzo // Example of use 

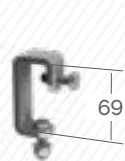

COD. **GA01**  **0,1**



COD. **GA02**  **0,3**

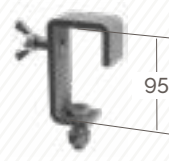

COD. **GA03**  **0,3**

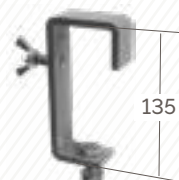

COD. **GA04**  **0,4**

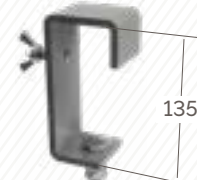

COD. **GA05**  **0,7**



COD. **GA30**  **0,2**



COD. **GA31**  **0,4**



COD. **GA32**  **0,4**



COD. **GA33**  **0,6**



COD. **GA50**  **0,2**



COD. **GA51**  **0,4**



COD. **GA52**  **0,4**



COD. **GA53**  **0,6**



COD. **GA54**  **0,7**



COD. **FA.14**



COD. **FA.18**



I ganci professionali antigraffio sono forniti all'interno di una linguetta che evita di graffiare il corrente del traliccio // *Our professional anti-scratch hooks are equipped with a flap which protects truss chords from scratching.*

La lunghezza della vite può essere su richiesta // *Screws of different lengths are available on request.*

COD.	MAX TUBO // TUBE MAX	SEZIONE // DIMENSIONS	PORTATA // LOAD CAPACITY
<b>GANCI // HOOKS</b>			
GA01	Ø 25 mm	25x5 mm	70 kg
GA02	Ø 30 mm	30x6 mm	130 kg
GA03	Ø 40 mm	30x6 mm	130 kg
GA04	Ø 50 mm	30x6 mm	75 kg
GA05	Ø 50 mm	50x6 mm	125 kg

<b>GANCI PROFESSIONALI // PROFESSIONAL HOOKS</b>			
GA30	Ø 25 mm	30x4 mm	45 kg
GA31	Ø 30 mm	40x6 mm	75 kg
GA32	Ø 40 mm	40x6 mm	75 kg
GA33	Ø 50 mm	50x6 mm	80 kg

<b>GANCI PROFESSIONALI ANTIGRAFFIO // ANTI-SCRATCH PROFESSIONAL HOOKS</b>			
GA50	Ø 25 mm	30x4 mm	45 kg
GA51	Ø 30 mm	40x6 mm	75 kg
GA52	Ø 40 mm	40x6 mm	75 kg
GA53	Ø 50 mm	50x6 mm	80 kg
GA54	Ø 80 mm	50x6 mm	70 kg

<b>FASCETTE ANTIGRAFFIO // ANTI-SCRATCH CLIPS</b>			
FA.14	Ø 14 mm		
FA.18	Ø 18 mm		

Misure indicate in mm // Dimensions in mm

## BINARI // TRACKS

Il binario in alluminio permette di **applicare teli e pannelli alla struttura in traliccio**. Al pannello vengono applicati i ganci in nylon Selvolina che scorrono all'interno del binario // *The aluminium track is designed to fix tarpaulins and panels to truss structures. Selvolina nylon hooks are fastened to the panel and slide along the track.*

## SISTEMA DI RIDISTRIBUZIONE DEL CARICO // LOAD REDISTRIBUTION SYSTEM

Piastre in alluminio necessarie per ridistribuire meglio sul traliccio il peso del carico sospeso // *Designed to redistribute the weight of a hanging load on a truss.*

Finitura standard in alluminio, altre finiture a richiesta // *Standard colour: aluminium. Other colours on request.*

COD. TRALICCIO // TRUSS CODE	COD. ACCESSORIO // ACCESSORY CODE	 KG
Q20S	Q20S.SRC	2,5 kg
Q20H	Q20H.SRC	2,5 kg
Q25S	Q25S.SRC	2,5 kg
Q25H	Q25H.SRC	2,5 kg
Q30S	Q30S.SRC	2,6 kg
Q30H	Q30H.SRC	2,7 kg
Q40H	Q40H.SRC	2,7 kg
Q50H	Q50H.SRC	2,9 kg

Binario in alluminio con foro di  $\varnothing$  18 mm fissato con rivetti o viti autoperforanti ogni 25 cm // *Aluminium track with  $\varnothing$  18 mm hole and fastened with rivets or self-drilling screws every 25 cm.*

### GANCIO IN NYLON // NYLON HOOK

Ogni binario è lungo fino a 6 m. In caso di strutture molto ampie, che necessitano di più binari, è possibile aggiungere una barra di ferro per allineare fra loro i binari // *Tracks are up to 6 m long. In case of large structures requiring more than one track, an iron rod can be inserted to align them.*

COD.	SEZIONE // SECTION	 KG
BS.09	$\varnothing$ 9 mm	0,2 kg
BS.18	$\varnothing$ 18 mm	0,6 kg



# COLONNE // COLUMNS

Ogni traliccio, quadrato o triangolare, può essere fornito con **base metallica**, per essere utilizzato in verticale. La colonna può essere fissata a terra e a muro e può sostenere vari elementi, come fari, altoparlanti, antenne e telecamere // *All our square and triangular trusses are available with a **base plate** for vertical installation. Columns can be fixed to the floor or the wall and can support various elements such as spotlights, speakers, antennae and video cameras.*



Base saldata al traliccio e non asportabile // *Non-detachable base plate welded to the truss.*



Base smontabile e asportabile // *Removable base plate.*

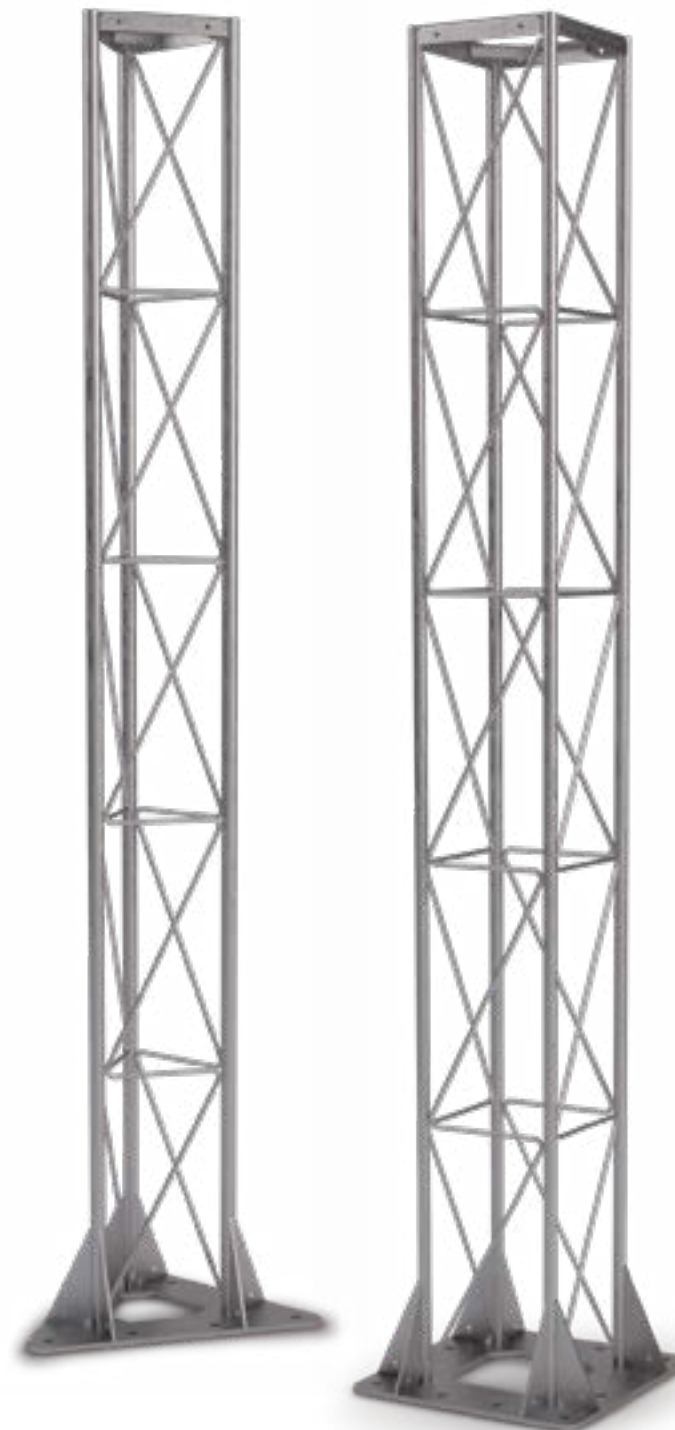

<b>CODICE TRALICCIO CON BASE COLONNA</b> // TRUSS · BASE PLATE CODE	<b>SEZIONE</b> // SIDE LENGTH	<b>LUNGHEZZA</b> // LENGTH	<b>CODICE PIASTRA PORTA ANTENNA</b> // ANTENNA PLATE CODE	<b>CODICE PIASTRA TENDI CAVI</b> // ROPE TIGHTENER CODE	<b>CODICE PIASTRA FISSAGGIO A MURO</b> // WALL PLATE CODE
<b>T30S.250B</b>	△ <b>30</b> cm	<b>250</b> cm	<b>T30S.PPA</b>	<b>T30S.PTC</b>	<b>T30S.PMC</b>
<b>Q25H.250B</b>	□ <b>25</b> cm	<b>250</b> cm	<b>Q25H.PPA</b>	<b>Q25H.PTC</b>	<b>Q25H.PMC</b>
<b>Q30S.250B</b>	□ <b>30</b> cm	<b>250</b> cm	<b>Q30S.PPA</b>	<b>Q30S.PTC</b>	<b>Q30S.PMC</b>
<b>Q30H.250B</b>	□ <b>30</b> cm	<b>250</b> cm	<b>Q30H.PPA</b>	<b>Q30H.PTC</b>	<b>Q30H.PMC</b>
<b>Q40H.250B</b>	□ <b>40</b> cm	<b>250</b> cm	<b>Q40H.PPA</b>	<b>Q40H.PTC</b>	<b>Q40H.PMC</b>
<b>Q50H.300B</b>	□ <b>50</b> cm	<b>300</b> cm	<b>Q50H.PPA</b>	<b>Q50H.PTC</b>	<b>Q50H.PMC</b>



COD. **T30S.PPA**  **5,8**

**Piastra porta-antenna //**  
*Antenna plate*



COD. **Q40H.PPA**  **12,2**

**Piastra porta-antenna //**  
*Antenna plate*



COD. **T30S.PTC**  **2,7**

**Piastra tendi-cavi //**  
*Rope tightener*



COD. **Q40H.PTC**  **4,8**

**Piastra tendi-cavi //**  
*Rope tightener*



COD. **T30S.PMC**  **5,2**

**Piastra di fissaggio a muro //**  
*Wall plate*



COD. **Q40H.PMC**  **11,0**

**Piastra di fissaggio a muro //**  
*Wall plate*

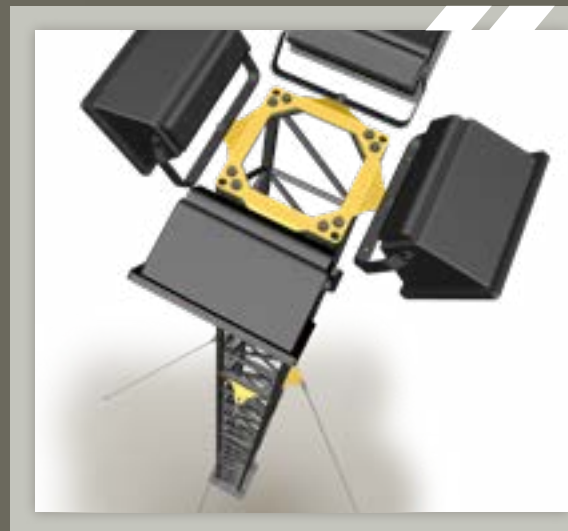

La piastra tendi-cavi può essere utilizzata sia per i cavi di stabilizzazione della colonna sia per il fissaggio di fari e altoparlanti //  
*The rope tightener can be used with column stabilizing ropes as well as spotlight and speaker fixing devices.*

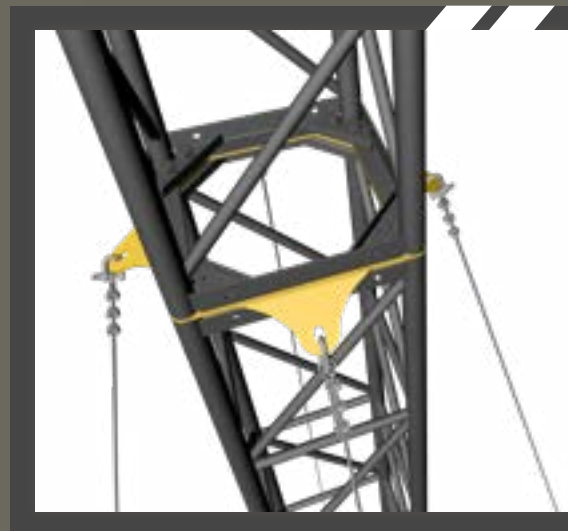



## Quella volta che... // The time when...

### STRUTTURE SPECIALI

#### PROGETTO DI TORRE PORTA FARI E ANTENNA PER L'ILLUMINAZIONE E LA SORVEGLIANZA DI UN PARCHEGGIO

Questo utilizzo speciale dei tralicci a colonna è di recentissima progettazione. In questo caso l'esigenza era quella di avere una struttura alta circa 15 m al centro di un parcheggio, che servisse sia per l'illuminazione che per il controllo dell'area sottostante, tramite il fissaggio di telecamere e sensori di movimento. La parte bassa della colonna è realizzata con un traliccio di sezione maggiore rispetto a quello superiore, questo per sfruttare la maggiore stabilità fisica delle strutture "piramidali". La parte superiore è dunque di sezione ridotta, questo rende la struttura non solo più stabile ma anche più leggera. Per sostenere i fari, l'antenna e le telecamere, è stato realizzato uno speciale cerchio metallico applicato alla cima, utile a fissare un maggior numero di fari rispetto allo standard e direzionare ogni elemento in modo indipendente. La presenza di antenna e sensori di movimento rendono indispensabile che la struttura sia molto stabile, per questo sono stati fissati a terra stralli e tiranti. Nella parte più bassa, inoltre, per ragioni di sicurezza, sono stati montati dei dissuasori per evitare la possibilità di arrampicarsi sulla colonna //

### SPECIAL STRUCTURES

#### CAR PARK LIGHTING AND ANTENNA SUPPORT TOWER PROJECT

This newly designed 15m-high tower system can be used as a support for spotlights as well as security cameras and motion sensors to monitor a car park. To get the most out of the physical stability of pyramid-shaped structures, a larger truss is used to construct the base of the tower. Since the upper part is narrower, the whole system is not only more stable but also lighter. A special metal circle has been installed on the top to support spotlights, cameras and an antenna. A greater number of spotlights can be supported than it is usually possible and each spotlight can be directed independently. Stay rods and tie-rods securely fix the tower to the ground given the additional weight of an antenna and motion sensors. For safety reasons, an anti-climb system has been installed.

Cerchio speciale per il fissaggio dei fari //  
Special circle for spotlight fixing.

Tralicci di sezione diversa per maggiore stabilità //  
Different-sized trusses for greater stability.

Stralli e tiranti per il fissaggio a terra //  
Stay rods and tie-rods for ground fixing.

12,5 m

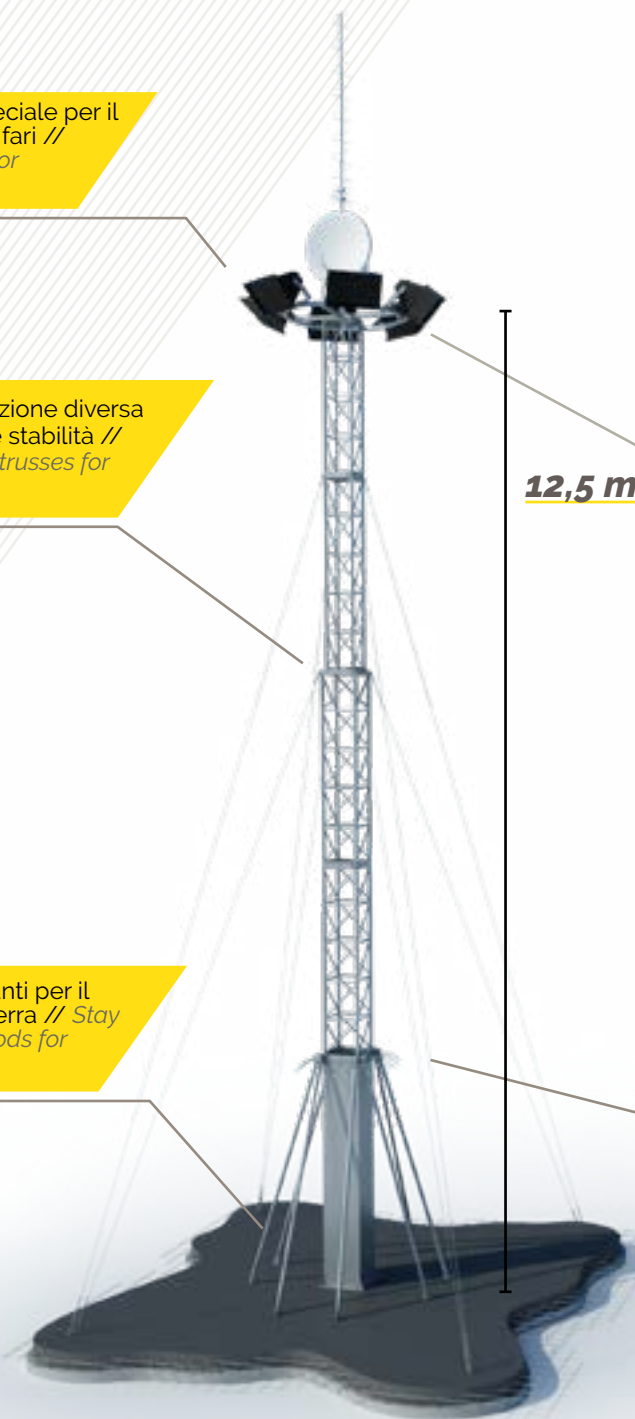



Cerchio speciale per fissaggio fari  
// Special circle for spotlight fixing.

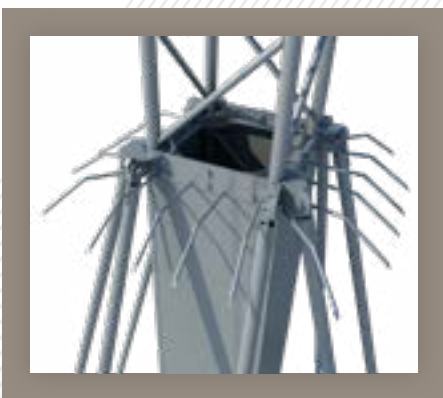

Dissuasori e carter di sicurezza //  
Anti-climb guards and security covers.



Alcuni esempi di  
realizzazioni //  
Examples of projects we  
have carried out.

